



**Before You Start:**

Please familiarize yourself with all the steps before beginning assembly.

**Compatibility Info:**

This Door System is designed to work with other Seizmik branded Accessories for the Polaris Ranger as well as OEM Polaris branded hard tops. Please note Seizmik cannot guarantee fitment with other branded aftermarket products. Please research installation details thoroughly on our products & others when trying to combine different branded accessories.

Seizmik makes Windshields, Mirrors, Cab Systems, Gun Holders, Light Bars, Hood Racks, and other great accessories for UTV's to maximize the vehicles usefulness.

If you have any questions, comments, need assistance, or are missing parts, please call 1-866-838-3366 between 9:00AM and 5:00PM EST or email us at [support@seizmik.com](mailto:support@seizmik.com). Visit [www.seizmik.com](http://www.seizmik.com) for more information on our products.



**WARNING:** This product is designed to protect from the elements of weather and is not designed for passenger retention purposes. Vehicle passengers should not lean on or against the doors. All passengers should wear seat belts while the vehicles is in use. Passengers leaning on or against the doors or failure of passengers to wear seat belts could result in serious bodily injury or death, especially when the vehicle is in operation.

# Polaris Ranger Doors Parts List

Parts shown are driver's side parts. You will have a mirrored part for passenger side. For item part numbers refer to the appendix at the back of these instructions.

## Door Subframe

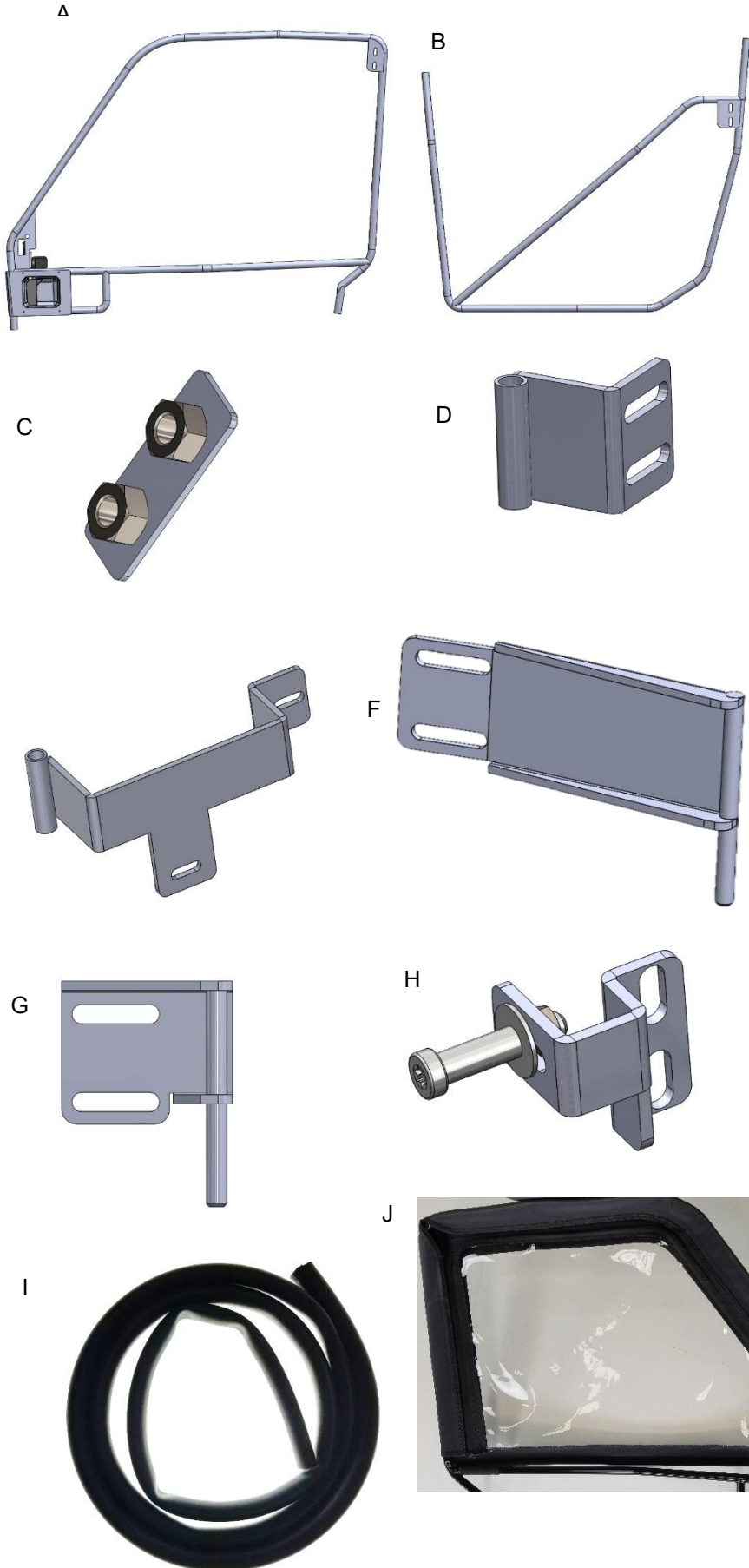

### Parts:

- A.Upper Door Subframe (Driver/Passenger)
- B.Lower Door Subframe (Driver/Passenger)
- C.Upper Backing Plate(x2)
- D.Upper Hinge Mount(x2)
- E.Lower Hinge Mount (Driver/Passenger)
- F.Lower Sliding Hinge (Driver/Passenger)
- G.Upper Sliding Hinge (Driver/Passenger)
- H.Striker Assembly (Driver/Passenger)
- I.Gasket 158" (x2)
- J.Upper Door Textile (Driver/Passenger)
- K.Lower Door Textile (Driver/Passenger)
- L. 6" Adhesive Hook Velcro Strips (x2)

### Hardware:

- M6 x 25mm button head bolt (x4)
- M6 Locknut (x4)
- M8 x 25mm flange hex head bolt (x8)
- M8 x 20mm flange hex head bolt (x4)
- M8 x 20mm button head bolt (x4)
- M8 Flanged Locknut (x8)
- M8 Locknut (x6)
- M8 Washers (x6)
- Striker Bolt (x2)

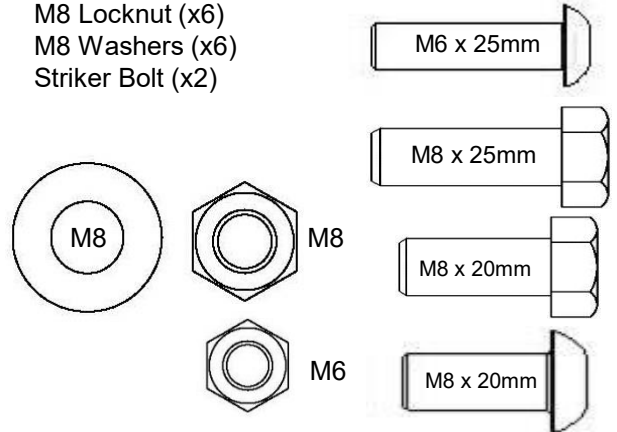

# 1. Installation of Mounting Plates

Driver's side shown. Repeat for Passenger side.

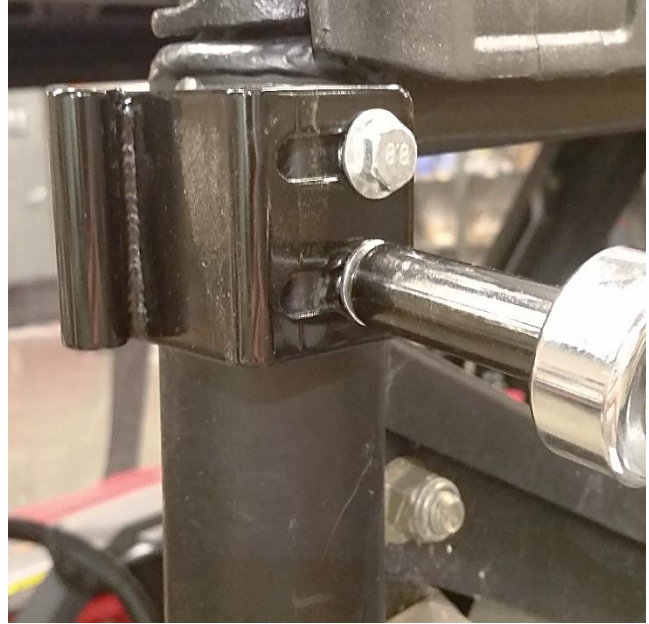

**1.** Install Upper Hinge Plate and Upper Backing Plate onto the mounting location at the upper rearward part of the ROPS structure. Install using M8x20mm fasteners and M8 Washers as shown. Do not fully tighten at this point as adjustments will need to be made when hanging the door structure.

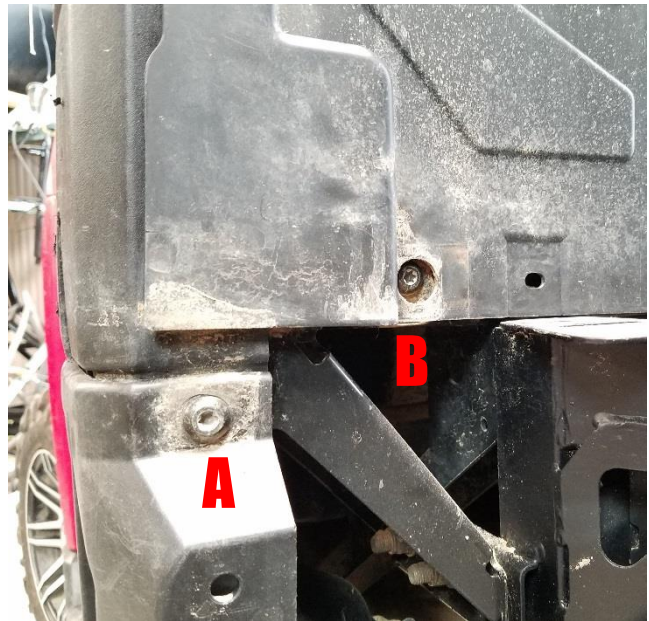

**2.** To install Lower Hinge Plate begin by moving the bed into the dump position. This is done in order to access the factory Torx head fasteners

**3.** Locate the factory Torx head fasteners at positions "A" and "B". These will be used to attach the Lower Hinge Plate. Remove fasteners.

# 1. Installation of Mounting Plates Cont.

Driver's side shown. Repeat for Passenger side.

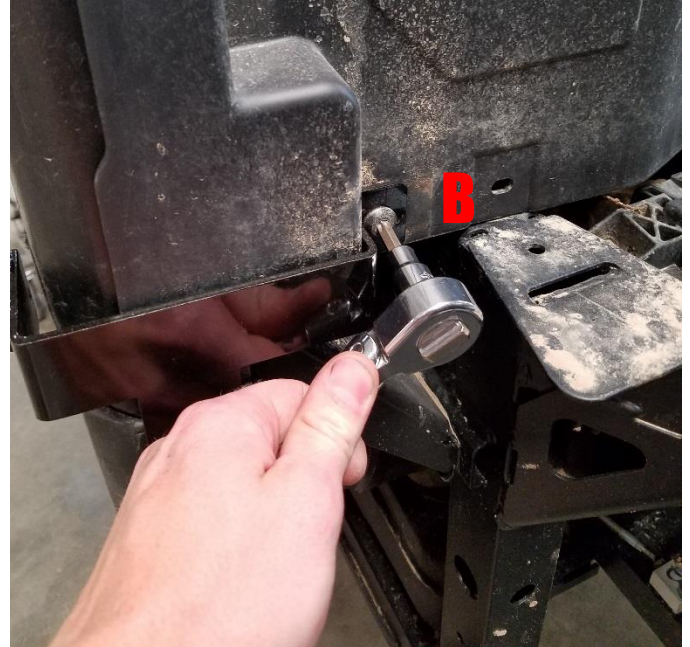
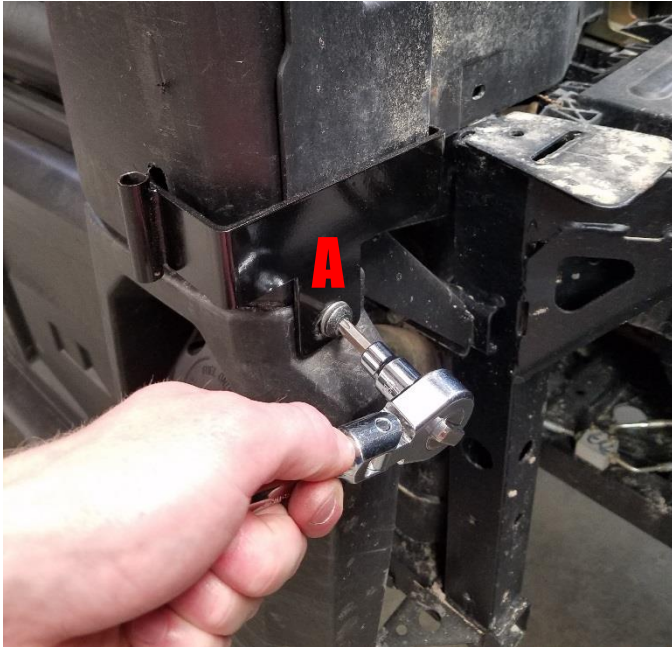

**4.** Install Lower Hinge Plate using factory Torx Head fasteners. (Body plastics may move when fasteners are removed. Be sure to realign holes to ensure the fasteners line up with the threaded holes in the sheet metal behind the plastics.)

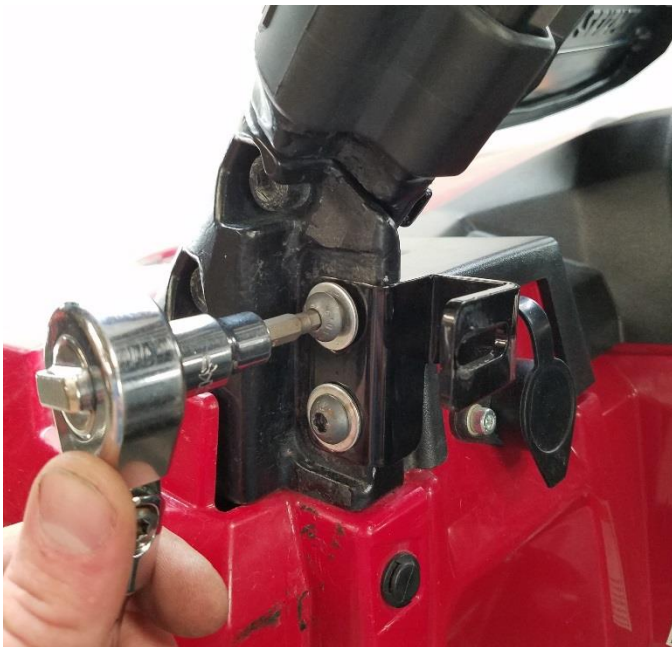

**5.** Move to the front corner of the ROPS structure. The Striker Plate will be installed using M8x20mm fasteners and M8 Washers in the holes provided on the ROPS structure as shown. (note these holes are slotted for striker adjustment. Do not fully tighten at this point.)

**6.** Attach striker bolt in the remaining slot on the Striker Plate in the orientation shown. Install with supplied nut. (This will adjust how far in and out the door is from the front of the body) (Do not fully tighten at this point.)

## 2. Door Construction



**7.** Locate attachment locations circled on both the Lower and Upper Door Frames. The sleeve tubing in the Upper door frame will slide into the tubing of the lower door frame.



**8.** Align Door frames, ensuring the two pieces are the same side (Both Driver sides, or both Passenger sides. Driver Door shown) and join the two door halves together. It will help to detach some of the Velcro on the lower door frame in order to make access to the tubing easier.

## 2. Door Construction Cont.



**9.** Attach Upper and Lower door frames using M6x25mm button head fasteners and corresponding M6 locknuts. The locknut should be on the inside of the door frame as shown.



**10.** Pull upper rear flap from lower door panel snugly over the door arm bar and secure flap to hook Velcro.

## 2. Door Construction Cont.



**11.** Next take the smaller upper flap and wrap around the forward part of the arm bar just behind the plastic molded pocket as shown. Secure flap around to hook Velcro.



**12.** Continuing down the door, attach long flap at the forward section of the lower door tubing to the hook Velcro on the inside of the panel.

**13.** At the rear of the lower door panel, wrap upper flap tightly around tubing to hook Velcro on the inside of the panel in the area shown.

## 2. Door Construction Cont.



**14.** Cut and place pieces of 1" wide adhesive hook Velcro onto plastic molded pocket in the areas outlined. This will keep the upper door textile secure at the front of the door.



**15.** Pull Upper door textile down firmly and attach to loop Velcro located on the outside of the lower panel as shown.



**16.** Pull Upper door textile and align the Velcro so that it attaches to the plastic molded pocket without obstructing handle movement.



### 3. Door Mounting



**17.** Holes need to be cut in door textile panels in order to mount the Upper and Lower Sliding Hinges. **Ensure textiles are tight and fit as desired before marking and cutting holes.** Take a sharp scribing tool and punch a small hole through the textile indicating the center of the slot. Take a razor blade and carefully cut out the small amount of textile so that the supplied M8 bolt may pass through the plate and the textile. Repeat this process for the lower mounting location.



**18.** Pass M8x25mm bolts through the Upper Sliding Hinge, textile, then the welded on door plate. Attach using M8 washers and lock nuts as shown. Repeat steps for Lower Sliding Hinge using M8x25mm bolts, M8 washers and lock nuts. Do not fully tighten at this time. Sliding Hinges are slotted for door adjustment.

## 4. Door Seal Installation



**19.** Clean the highlighted area of the ROPS structure and bodywork with rubbing alcohol or window cleaner. **(Failure to clean ROPS structure and bodywork will result in gasket falling off and doors not sealing properly!)** Adhere the provided gasket into the outer channel of the roll cage as shown by the highlighted area above. Be sure the gasket is oriented the same as the image above.

## 5. Door Adjustment

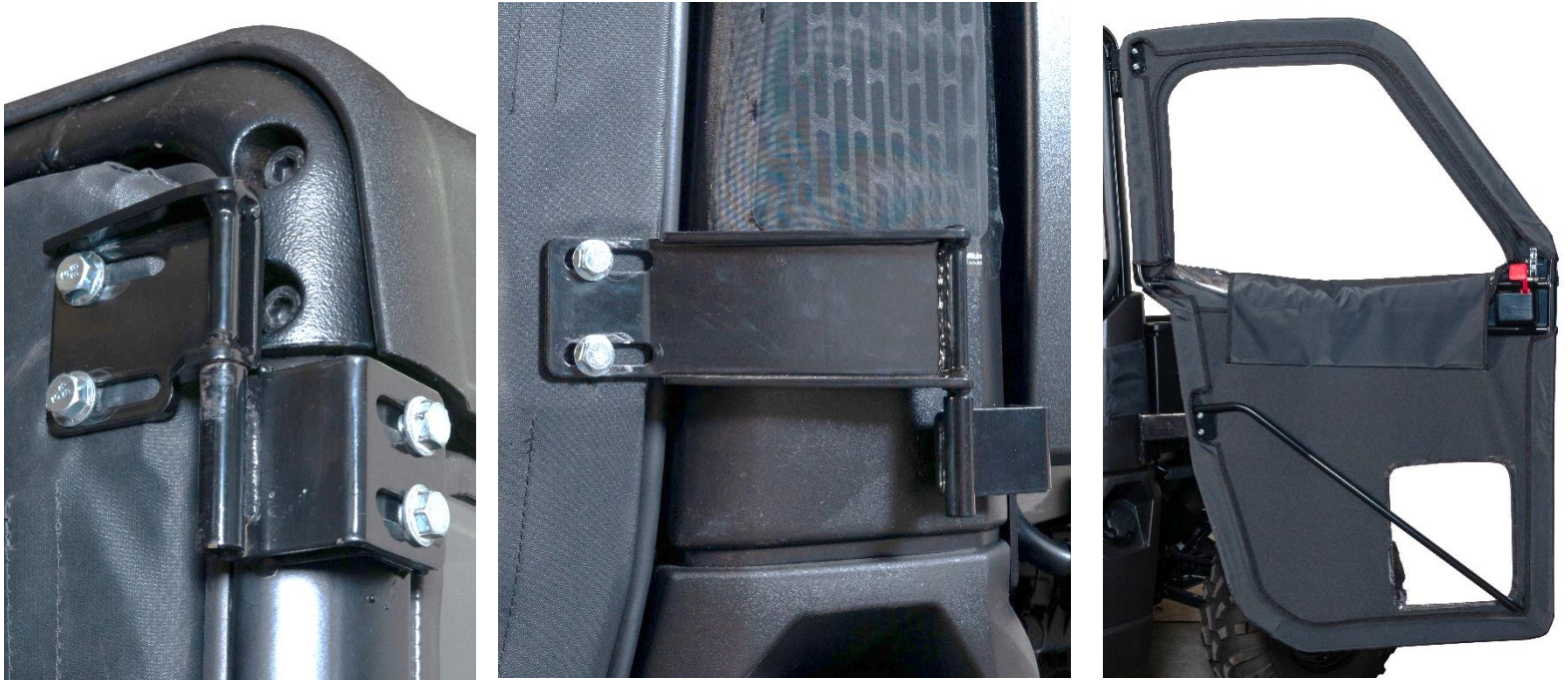

**20.** Insert the Sliding Hinge Pins into the Hinge Mount Barrels and roll down the window for easier adjustment.



**21.** Move the door into the “closed” position. With the window down, you can access the striker plate from the outside of the vehicle to make adjustments easier.



**22.** We have found that placing a piece of scrap cardboard at the bottom edge as shown will help line up the door so that it will not drag on the bodywork when the door is finished being adjusted.

## 5. Door Adjustment



**23.** With the striker bolt loose and door pressed firmly against the body work and gasket, move the striker bolt into the closed position of the rotary latch. There should be two clicks when it is fully latched. Note the location of the striker bolt on the striker plate. This will give you a good starting point for adjusting the door.



**24.** Open the door and tighten the striker bolt to the plate. Leave the two bolts attached to the ROPS structure loose so that the assembly may move up and down.



**25.** Move the door back into the closed position, again pressed firmly against the gasket on the bodywork. This may require you to move the striker assembly up or down in order for the latch to fully engage. At this point tighten the door plate bolts just enough to keep the door from sliding forward and back.

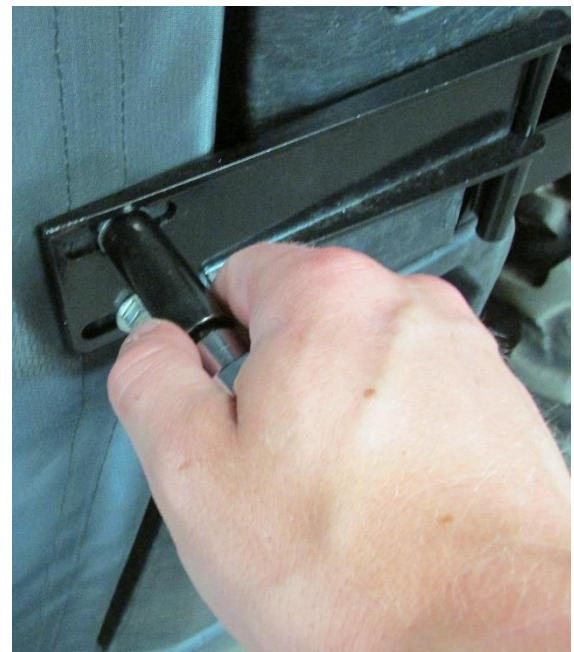

## 5. Door Adjustment

**26.** The most critical part of adjusting the door is ensuring the striker bolt and latch line up correctly. If they do not, the door may not close fully or may be difficult to do so.

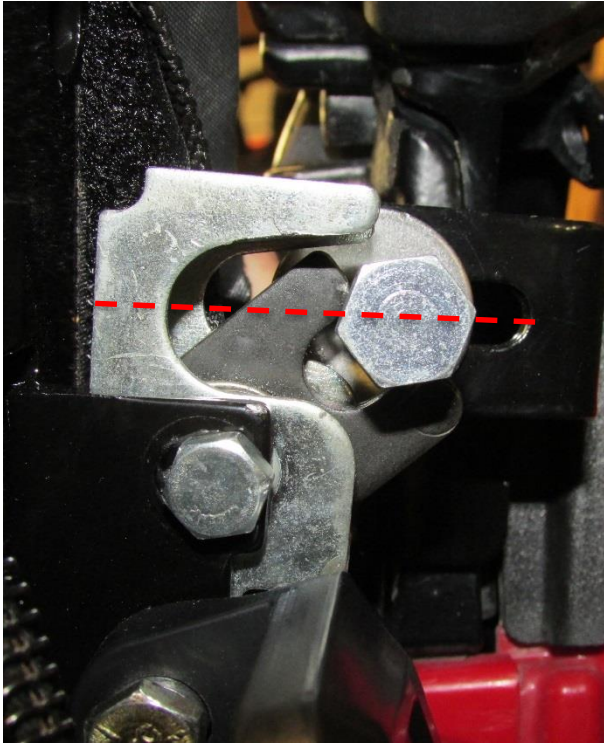

**27.** Shown above is the correct alignment for the striker bolt and latch just before the door is closed. The bolt should line up in the center of the relief in the latch. This will allow the door to close smoothly.

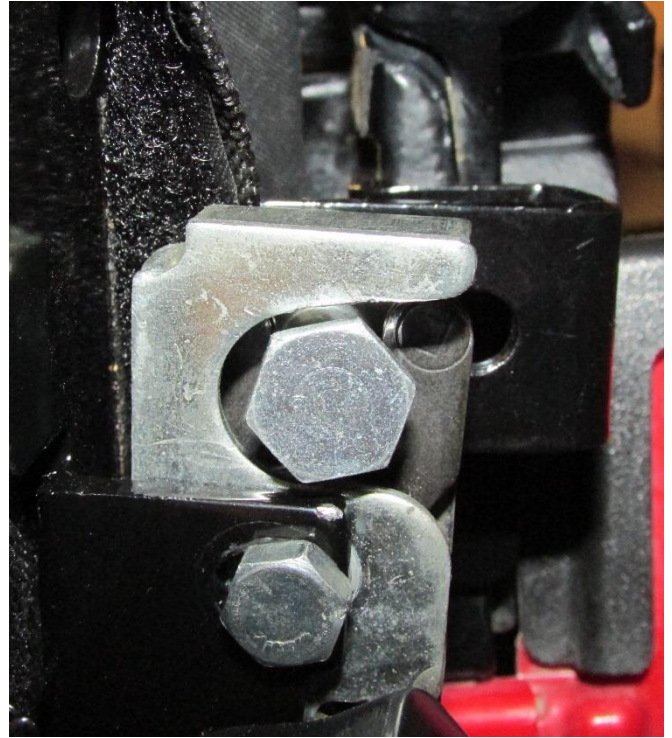

**28.** Shown above is the correct alignment for the striker bolt and latch when the door is fully closed.

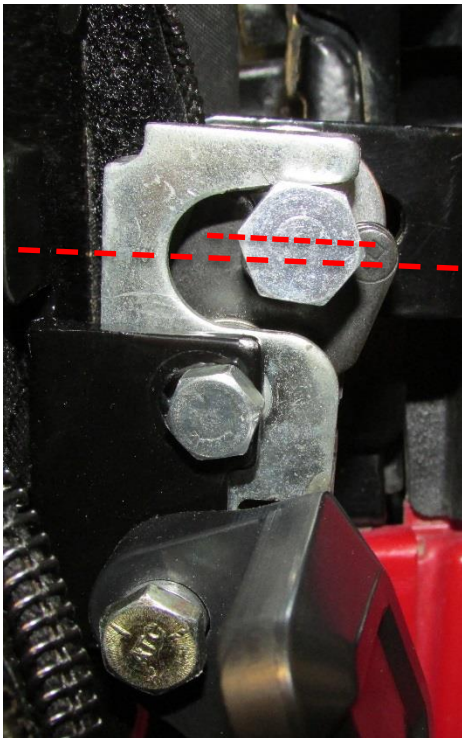

**29.** In the image above the striker is aligned incorrectly. Note the latch is not fully closed and the striker bolt is not aligned in the center.

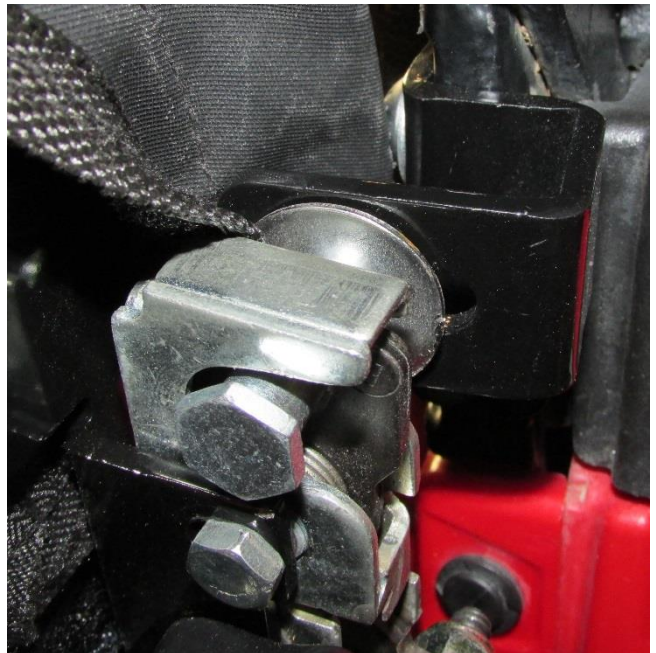

**30.** The door should be adjusted in the forward/rearward direction so that the striker bolt head does not contact the latch. The image above shows the correct positioning of the striker bolt.

## 5. Door Adjustment

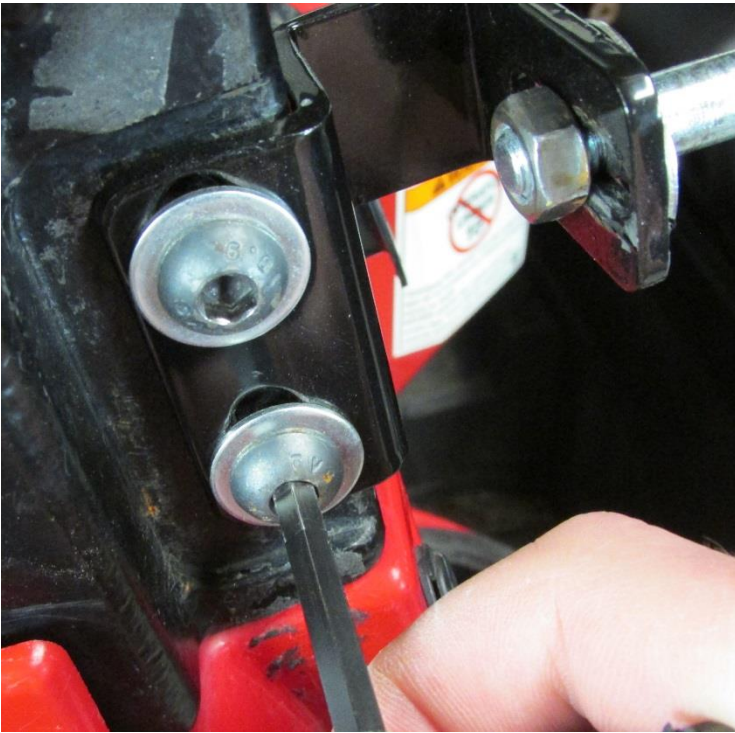

**31.** With the striker bolt in the correct location, fully tighten down the striker bolt to the striker plate and fully tighten the plate to the ROPS Structure.



**32.** The Upper Hinge mount plate may be adjusted in and out to affect how much the door will compress the gasket.  
-Moving this outward, away from the vehicle, should allow the door to close more easily but will not compress the gasket as much.  
-Moving this inward, towards the center of the vehicle will compress the gasket more creating a better seal, but may make the door more difficult to close.



**33.** Once the door has been adjusted as desired, fully tighten down all fasteners on door hinge sliding plates, and hinge mounts. Before operation, ensure all Velcro is securely fastened.

**IMPORTANT:** Due to production differences between vehicles, there is a chance that even after following these adjustment procedures you will have gaps between the door and the sealing weatherstrip. If this happens, you can just carefully pull on the door frame and bend it until it seals. Don't worry, you won't break it.

## 6. Installing Mirrors with Soft Doors (Opt.)

Driver's side shown. Repeat for Passenger's side.



**34.** Locate the mirror mounting bracket on the inside of the door frame. Mark the location of the hole with a punch so that it can be seen on the outside of the door textile.



**35.** Using a sharp razor or utility knife, cut the textile so the mirror mounting bolt can pass through.



**36.** Pass the bolt through the mounting bracket and thread into the mirror and tighten (DO NOT OVER TIGHTEN).

## APPENDIX

Full Size Ranger Pro-fit Doors (06022)		
Item #	Part#	Description
A	54-SW-90280	Upper Door frame <b>driver side</b>
A	54-SW-90281	Upper Door frame <b>passenger side</b>
B	54-SW-90282	Lower door frame <b>driver side</b>
B	54-SW-90283	Lower door frame <b>passenger side</b>
C	54-SW-90284	upper backing plate
E	54-SW-90285	Lower hinge mount <b>driver side</b>
E	54-SW-90286	Lower hinge mount <b>passenger side</b>
D	54-SW-90287	Upper hinge mount
F	54-SW-90288	Lower Sliding Hinge <b>driver side</b>
F	54-SW-90289	Lower sliding hinge <b>passenger side</b>
G	54-SW-90290	Upper Sliding Hinge <b>driver side</b>
G	54-SW-90291	Upper Sliding Hinge <b>passenger side</b>
H	54-SW-90292	Striker Assembly <b>driver side</b>
H	54-SW-90293	Striker Assembly <b>passenger side</b>
I	54-SW-90294	Self adhesive door bulb gasket 158"
J	54-SW-90295	Upper Door Textile <b>driver side</b>
J	54-SW-90296	Upper Door Textile <b>passenger side</b>
K	54-SW-90297	Lower Door Textile <b>driver side</b>
K	54-SW-90298	Lower Door Textile <b>passenger side</b>
L	54-SW-90299	30" Adhesive Hook Velcro Strips [6"(x4), 3"(x2)]
	54-SW-90300	Striker Bolt
	54-SW-90301	Plastic door handle pocket <b>driver side</b>
	54-SW-90302	Plastic door handle pocket <b>passenger side</b>
	54-SW-90303	Plastic door release handle <b>driver side</b>
	54-SW-90304	Plastic door release handle <b>passenger side</b>
	54-SW-90305	Rotary latch <b>driver side</b>
	54-SW-90306	Rotary latch <b>passenger side</b>
	54-SW-90976	DOOR HANDLE BUSHING
	54-SW-90307	Hardware kit

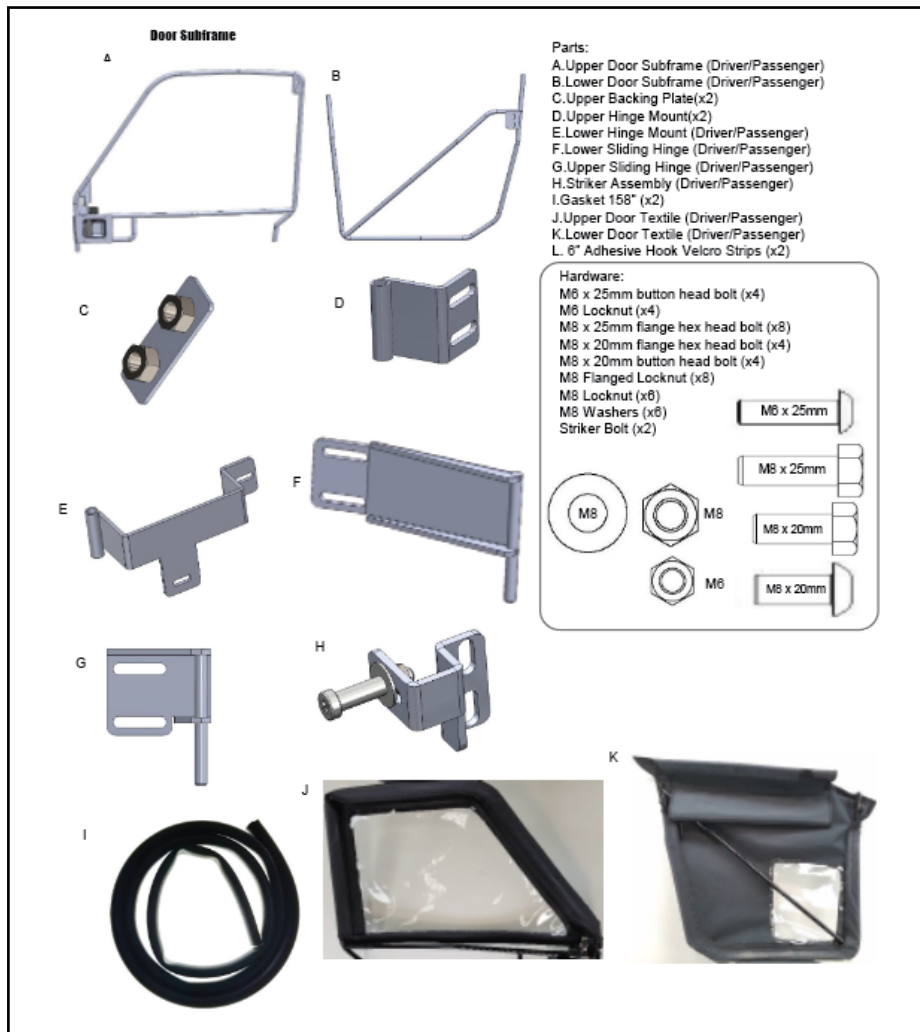

# Polaris Ranger Doors Parts List

Parts shown are driver's side parts. You will have a mirrored part for passenger side. For item part numbers refer to the appendix at the back of these instructions.

## Door Subframe

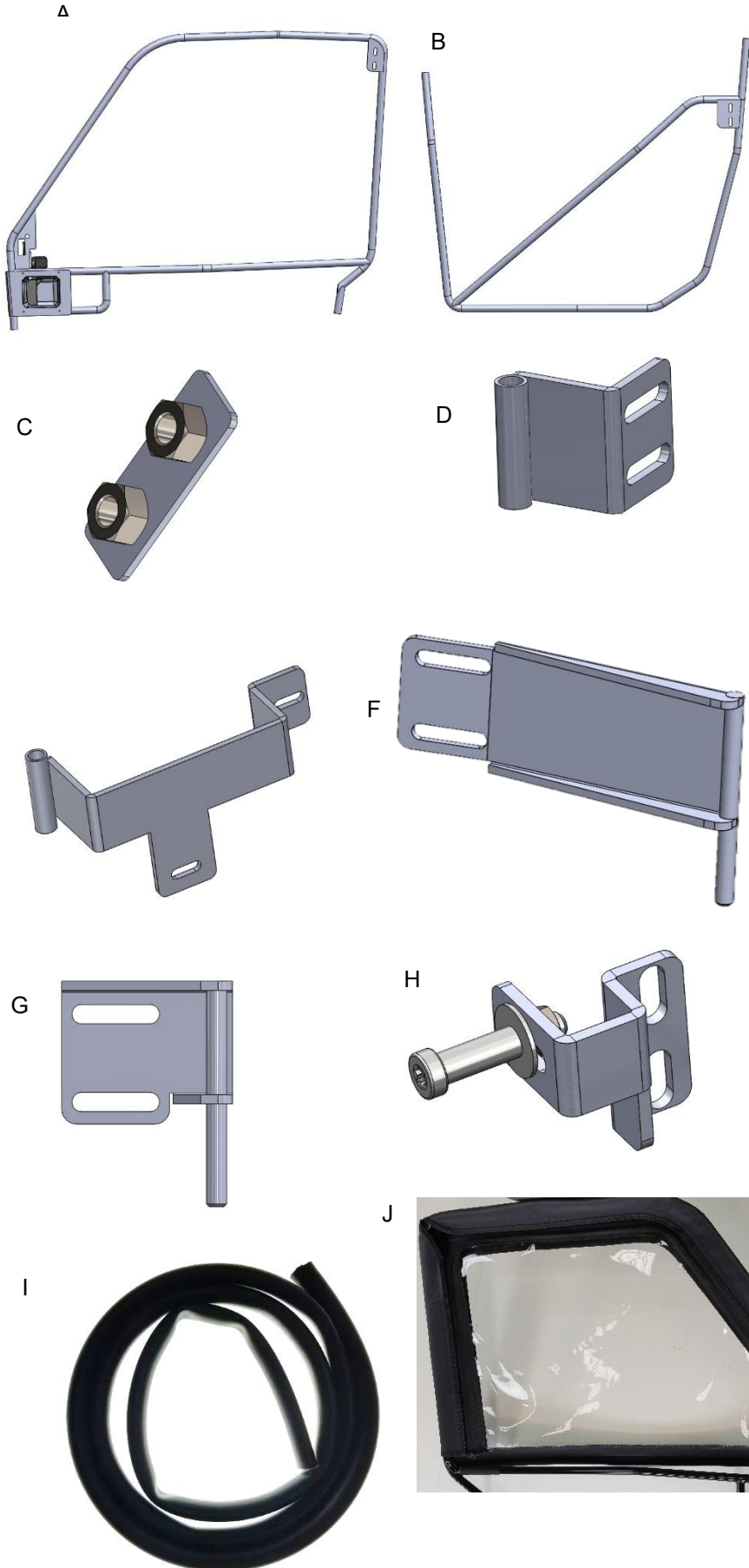

### Parts:

- A.Upper Door Subframe (Driver/Passenger)
- B.Lower Door Subframe (Driver/Passenger)
- C.Upper Backing Plate(x2)
- D.Upper Hinge Mount(x2)
- E.Lower Hinge Mount (Driver/Passenger)
- F.Lower Sliding Hinge (Driver/Passenger)
- G.Upper Sliding Hinge (Driver/Passenger)
- H.Striker Assembly (Driver/Passenger)
- I.Gasket 158" (x2)
- J.Upper Door Textile (Driver/Passenger)
- K.Lower Door Textile (Driver/Passenger)
- L. 6" Adhesive Hook Velcro Strips (x2)

### Hardware:

- M6 x 25mm button head bolt (x4)
- M6 Locknut (x4)
- M8 x 25mm flange hex head bolt (x8)
- M8 x 20mm flange hex head bolt (x4)
- M8 x 20mm button head bolt (x4)
- M8 Flanged Locknut (x8)
- M8 Locknut (x6)
- M8 Washers (x6)
- Striker Bolt (x2)

